

■

■

■



1.

1.1

()

1.1

2

1.2

1.3

:
2Cr13 304 316

NBR PTFE

:
JIS B2220 GB2506-89

1.4

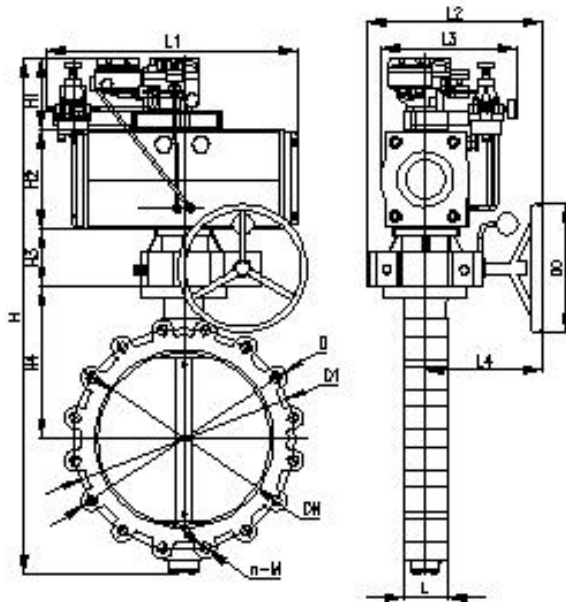

DW	L	L1	L2	L3	L4	D0	D	D1	H1	H2	H3	H4	H	n-N	type
100	82	420		320			220	180		100.0		178	646	3-1118	WAFK30
125	58	448	247	320	192		250	210		116.5	38	190.5	705	8-1116	WAFK20
150	58	448		320		200	285	240		118.5		190	720	3-1120	WAFK20
200	82	498	284.5	330			340	285		130		218	828	6-1120	WAF1200
250	88	466		340	202.5		385	350	184	172		283	815	12-1120	WAF1400
300	78	541		360	233		445	400		197		308	885	12-1120	WAF1600
350	78	581		370			505	490		230		330	1140	18-1120	WAF1900
400	102	581	407.5	370		300	585	515		250		355.5	1200	18-1124	WAF1900
450	114	430		400	272.5	300	615	665		289	130	410	1360	20-1124	WAF2400
500	127	630	442.5	405	302.5	400	670	630		289		441	1440	20-1124	WAF2400
700	185	777	813	430	485	500	825	840		350	248	570	1840	24-1127	WAF3228

1.5

1.0MPa
0.7MPa

2.1

22

23

3

3.1

3.1.1

3.1.2

a.

b.

c.

d.

e.

f.

g.

h.

3.2

3.2.1

3.2.2

3.2.3

3.2.4

3.2.5

4

4.1

4.1.1

4.1.2

4.1.3

4.1.4

4.2

	1. 2 3.	1. 2 3.
	1. 2	1. 2
	1. 2	1. 2

5.

5.1

5.2

5.3

